

This article was downloaded by:

On: 16 January 2011

Access details: *Access Details: Free Access*

Publisher *Taylor & Francis*

Informa Ltd Registered in England and Wales Registered Number: 1072954 Registered office: Mortimer House, 37-41 Mortimer Street, London W1T 3JH, UK



Liquid Crystals Today

Publication details, including instructions for authors and subscription information:

<http://www.informaworld.com/smpp/title~content=t713681230>

Modal liquid crystal lenses

Gordon D. Love^a; Alexander F. Naumov^a

^a Department of Physics and School of Engineering, University of Durham, Durham DH1 3LE, UK,

Online publication date: 11 November 2010

To cite this Article Love, Gordon D. and Naumov, Alexander F.(2000) 'Modal liquid crystal lenses', *Liquid Crystals Today*, 10: 1, 1 – 4

To link to this Article: DOI: 10.1080/135831401750061465

URL: <http://dx.doi.org/10.1080/135831401750061465>

PLEASE SCROLL DOWN FOR ARTICLE

Full terms and conditions of use: <http://www.informaworld.com/terms-and-conditions-of-access.pdf>

This article may be used for research, teaching and private study purposes. Any substantial or systematic reproduction, re-distribution, re-selling, loan or sub-licensing, systematic supply or distribution in any form to anyone is expressly forbidden.

The publisher does not give any warranty express or implied or make any representation that the contents will be complete or accurate or up to date. The accuracy of any instructions, formulae and drug doses should be independently verified with primary sources. The publisher shall not be liable for any loss, actions, claims, proceedings, demand or costs or damages whatsoever or howsoever caused arising directly or indirectly in connection with or arising out of the use of this material.

Modal liquid crystal lenses

GORDON D. LOVE* and ALEXANDER F. NAUMOV

Department of Physics and School of Engineering,
University of Durham, Durham DH1 3LE, UK

The ability of liquid crystals to control the *phase* of a beam of light, as well as its intensity, has meant that there is a large body of research which has built up on their non-display applications. The use of homogeneously aligned LCs to control wavefront shapes has been exploited in order to make electrically switchable optical elements, such as prisms, lenses, or more complicated wavefront controllers [1] for adaptive optics.

Here we describe some of our latest work on using liquid crystal devices as lenses, and on a method of electrically addressing the LCs to produce smooth profiles without the use of pixels.

A conventional fixed lens can be thought of as a device which produces a phase shift across the beam, as a function of distance. It achieves this by being a medium of constant refractive index (usually glass), with a variable

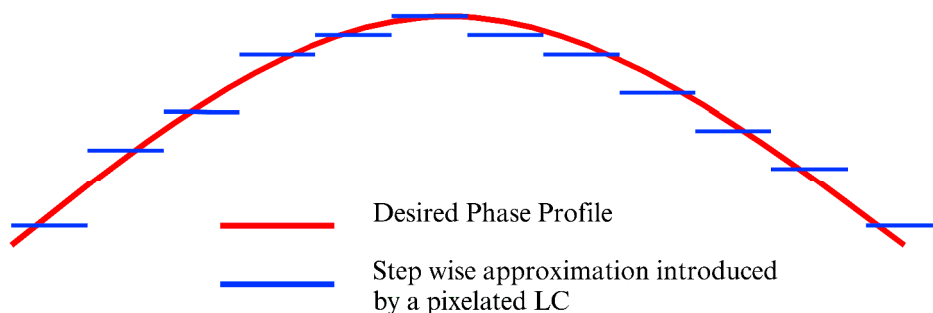

Figure 1. Approximating a continuous phase profile (red line) with a zonal (pixelated) liquid crystal (blue line).

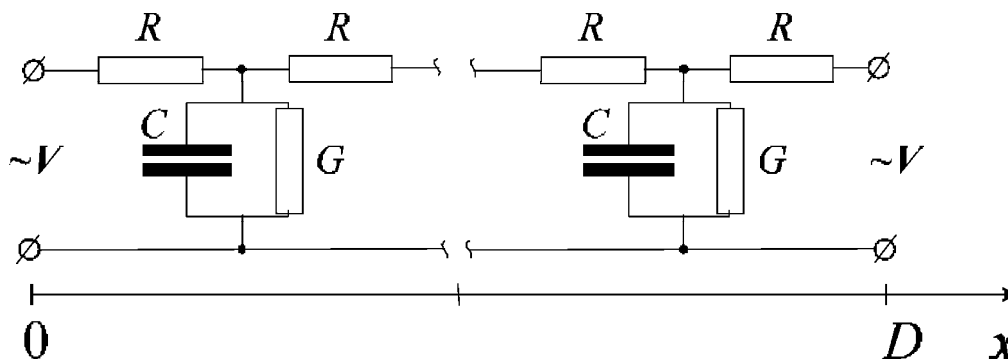

Figure 2. The electrical equivalent of the LC lens shown in figure 1. Voltage V is applied to either end. The series of resistors, R , correspond to the top electrode, and the series of capacitors and conductances, C and G , correspond to the LC layer. Note the similarities with a transmission line.

* Author for correspondence e-mail: g.d.love@durham.ac.uk

thickness across the lens. A LC device can achieve the same result by keeping the physical thickness constant, and by tuning the refractive index. Cylindrical LC lenses have been made by using an array of linear electrodes and circular lens structures have been produced using a Fresnel lens structure. Some past work on LC lenses is given in [2–4].

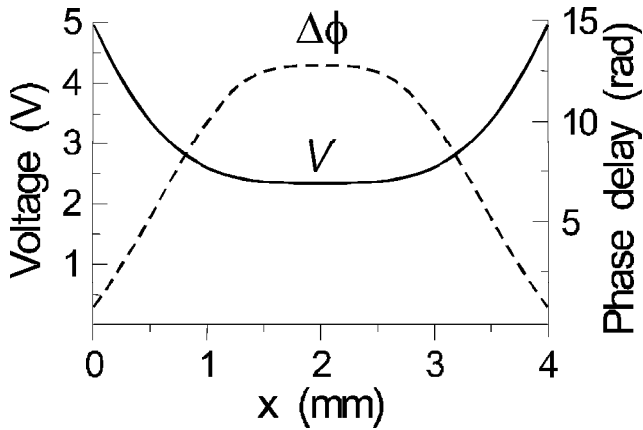

Figure 3. Resultant voltage profile (V) and phase profile across a modal LC lens.

In parallel with displays, most LC lenses are *zonal*, i.e. different areas of the device are addressed by a patterned array of electrodes, or pixels used to supply the control voltages. These pixels can be on a rectangular grid, as is the case in a display, or could be in the form of concentric rings, in order to build a Fresnel lens structure. The net result is that the shape of the phase profiles produced depend on the geometrical arrangement of the pixels, and furthermore, the phase steps between neighbouring pixels must be limited, otherwise diffraction will occur. In summary, a zonal LC lens operates by approximating the desired continuous wavefront shape with a step-wise approximation defined by the pixel structure. This is shown pictorially in figure 1 below.

We have developed an alternative method for controlling LCs which can produce continuous phase profiles, without the need for pixels, which we call *modal addressing* [5, 6]. The modal principle utilizes the fact that a LC cell can be modelled as an electrical circuit, which is very similar to a transmission line. A modal liquid crystal lens is simply a single switchable cell of homogeneously aligned LC material which has a very high resistance electrode (typically $M\Omega/\square$), and figure 2 below shows its electrical equivalent.

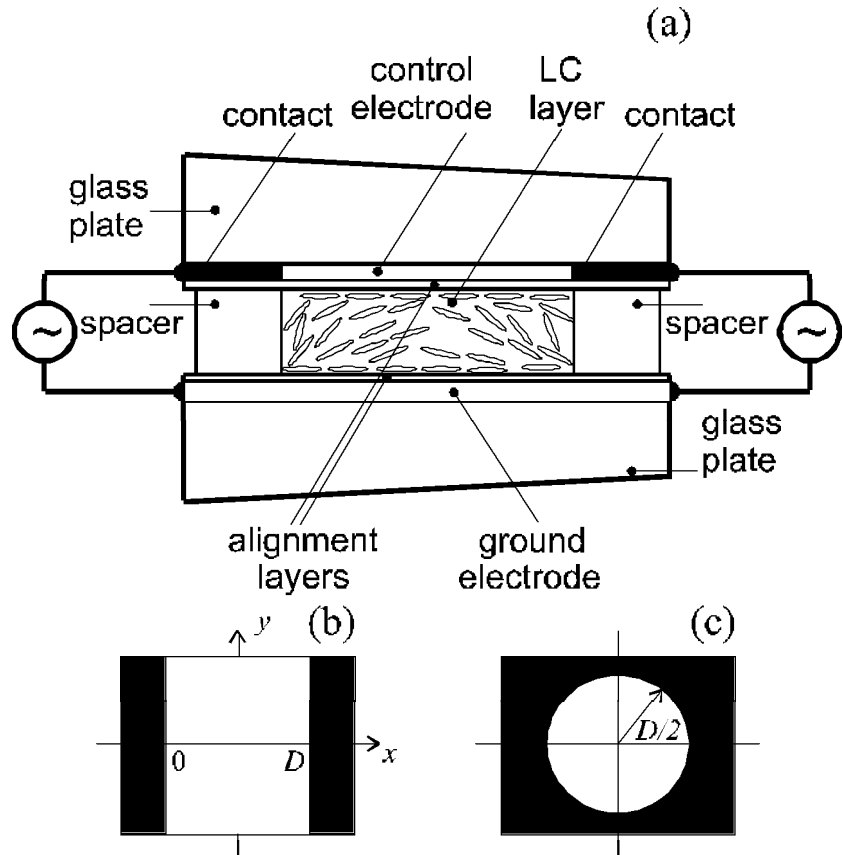

Figure 4. Construction of a modal LC lens. The top diagram shows a conventional LC cell, except that the top electrode is of very high resistance. The bottom two figures show plan views looking down onto the lenses and the arrangement of the low resistance contact electrodes to give a cylindrical (left) and circular (right) lens.

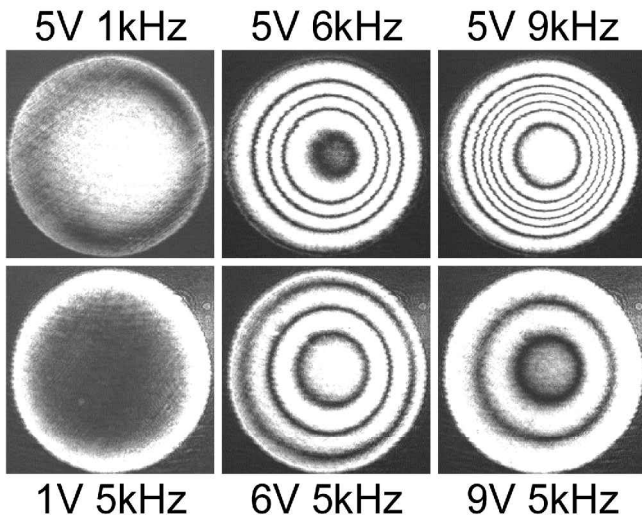

Figure 5. Interferograms (produced by placing the device between crossed polarizers) from a spherical LC lens, for different values of applied voltage (rms) and frequency.

The resistors correspond to the high resistance electrode, and the capacitors and conductances correspond to the LC material. D is the cell size and an ac voltage, V , is applied to both ends. The resulting voltage and phase profile across such a device is shown in figure 3.

Notice that a varying phase profile across the device has been produced without the use of pixels. Either cylindrical (1-dimensional) or circular (2d) modal lenses can be produced by changing the shape of the electrical contacts, as shown in figure 4.

The resulting power of the lens depends on the controllable phase range of the LC, but typically lenses with f ratios varying from 100 to ∞ are achievable. The lens shown below has a 5 mm diameter, with a minimum focal length of 50 cm. The lenses can be controlled either by varying the amplitude of the voltage, or the applied frequency. Figure 5 shows a sequence of interferograms showing lens control with either a fixed frequency, or a fixed voltage.

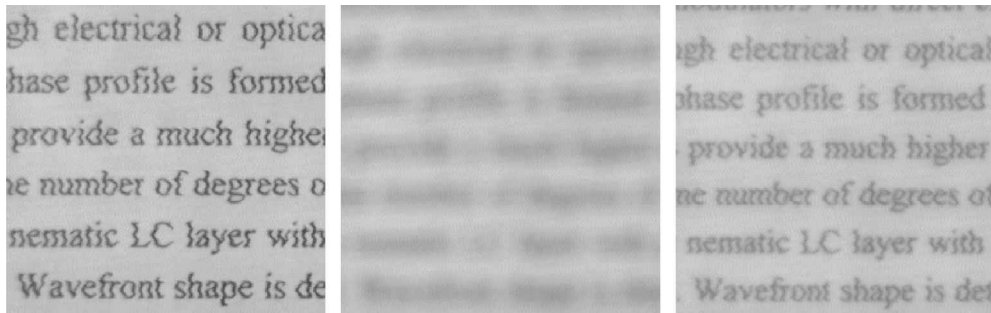

Figure 6. Example of a LC lens producing an image. (Left) lens off, system adjusted to give a good focus. (Middle) System mechanically adjusted to induced defocus. (Right) LC lens turn on to correct for induced defocus.

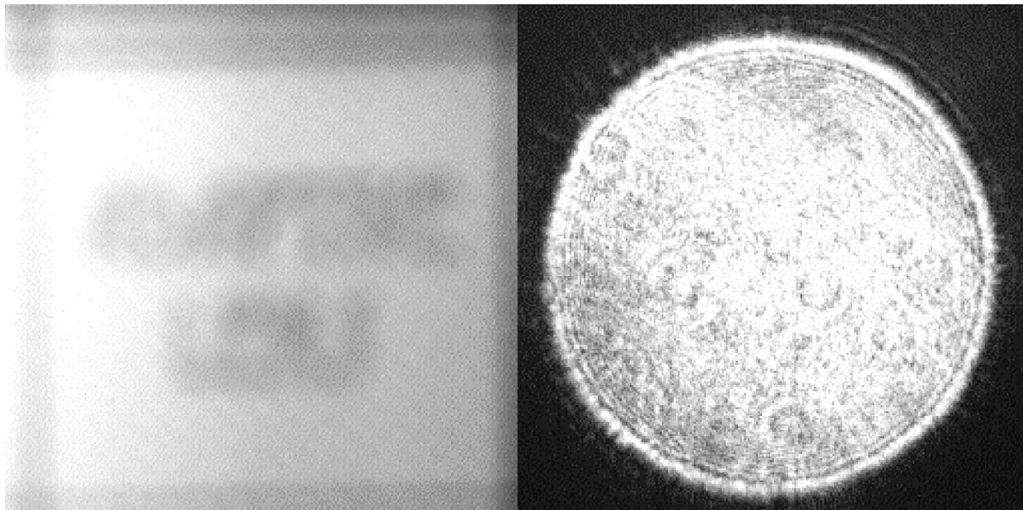

Figure 7. There is an animated version of this figure available at <http://www.catchword.com/tandf/images/lqlens.gif> showing adaptive focusing with the lens, demonstrating both the changing focus and the resulting interferogram.

Figure 6 shows the effect of focusing using a modal LC lens. A simple imaging system was set up using fixed lenses to focus some text onto a CCD camera. The LC lens was placed in the system, but turned off. One of the fixed lenses was displaced in order to defocus the image, and this was subsequently corrected with the LC lens.

In summary, modal addressing of LC lenses allows the construction of lenses with continuously variable focal lengths which do not diffract light at the pixel boundaries, and which are very simple to construct. The limiting factor for most applications is their relatively short focal length.

References

- [1] LOVE, G. D., 1997, *Appl. Opt.*, **36**, 1517.
- [2] FOWLER, C. W., and PATERAS, 1990, *Ophthalm. Physiol. Opt.*, **10**, 186.
- [3] NOSE, T., MASUDA, S., and SATO, S., 1992, *Jpn. J. appl. Phys.*, **31**, 1643–1646.
- [4] LAUDE, V., 1998, *Opt. Commun.*, **153**, 134.
- [5] NAUMOV, A. F., LOKTEV, M. YU., GURALNIK, I. R., and VDOVIN, G. V., 1998, *Opt. Lett.*, **23**, 992.
- [6] NAUMOV, A. F., LOVE, G. D., LOKTEV, M. YU., and VLADIMIROV, F. L., 1999, *Opt. Express*, **4**, 344; <http://epubs.osa.org/opticsexpress/framestocv4n9.htm>